

Delivering Real American Value

At Lift Company of America, we know that materials handling equipment customers demand value... so that's what we deliver.

Here's how.

Quality Manufacturing - Our lift manufacturing process follows strict guidelines and uses a combination of the most current equipment along with proven techniques generated over decades of experience. All products are manufactured in accordance with ANSI MH29.1 standards.

Reliable Performance - Every item we sell is tested and retested to ensure it meets the highest possible performance standards.

Durability - We measure the useful life of our products in decades, not months or years like some competitors. By meshing proven designs with application experience and quality manufacturing, we provide products that consistently exceed expectations.

Custom Engineering - Our standard product line has been developed to satisfy virtually any application requirement. However, should the need for standard modifications or even custom design arise, we have the application and engineering support to provide it.



Compact Lifts



All the performance features and benefits of a standard lift table in a compact package.

- Lifting heights from 36" to 76"
- Capacities from 500 to 2,500 pounds
- Platform sizes up to 48" x 72"
- 115V power operated by push button pendant or foot switch control

Model	Capacity	Low Height	Vertical Travel	Standard Platform	Max Platform	Minimum Platform	Motor	Power	Rise Time	Weight
CBD-25-005	500 lbs.	6"	30"	12" x 24"	12" x 24"	12" x 24"	1/2 HP	115/1/60	20 sec.	175 lbs.
CBD-30-010	1,000 lbs.	6"	30"	16" x 24"	24" x 36"	16" x 24"	1/2 HP	115/1/60	20 sec.	225 lbs.
CBD-36-020	2,000 lbs.	6"	36"	24" x 48**	42" x 60"	18" x 31"	1/2 HP	115/1/60	35 sec.	390 lbs.
CBD-36-040	4,000 lbs.	7"	36"	24" x 48"	48" x 72"	24" x 35 1/4"	1 HP	115/1/60	30 sec.	825 lbs.
CBD-48-015	1,500 lbs.	6"	48"	24" x 52"	30" x 72"	18" x 38 3/4"	1/2 HP	115/1/60	35 sec.	425 lbs.
CBD-48-040	4,000 lbs.	12"	48"	30" x 42"	48" x 60"	30" x 42"	3.2 HP	460/3/60	16 sec.	1,250 lbs.
CBD-60-025	2,500 lbs.	12 1/2"	64"	24" x 53"	42" x 66"	24" x 53"	3.2 HP	460/3/60	16 sec.	1,100 lbs.

*18" x 42" Platform is also available as standard on this model.

Standard Use Lift Tables

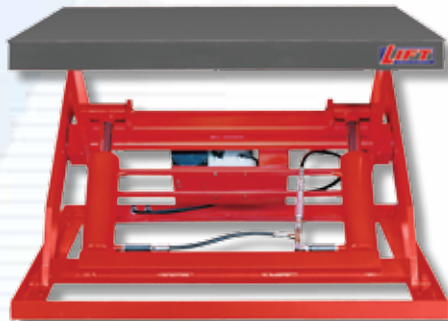

Our most popular lift tables. Well suited to a wide variety of manufacturing, work positioning and assembly uses.

- LIFTING HEIGHTS UP TO 70"
- CAPACITIES FROM 1,000 TO 8,000 POUNDS
- PLATFORM SIZES UP TO 48" x 120"
- OPERATED BY PUSH BUTTON PENDANT OR FOOT SWITCH CONTROL

Model	Capacity	Low Height	Vertical Travel	Standard Platform	Max Platform	Motor	Power	Rise Time	Weight
BD-36-010	1,000 lbs.	5 1/4"	36"	24" x 48"	36" x 60"	1/3 HP	115/1/60	29 sec.	425 lbs.
BD-36-015	1,500 lbs.	5 1/4"	36"	24" x 48"	36" x 60"	1/3 HP	115/1/60	36 sec.	430 lbs.
BD-36-020	2,000 lbs.	7 1/4"	36"	24" x 48"	48" x 72"	1 HP	115/1/60	17 sec.	690 lbs.
BD-36-030	3,000 lbs.	7 1/4"	36"	24" x 48"	48" x 72"	1 HP	115/1/60	30 sec.	720 lbs.
BD-36-040	4,000 lbs.	7 1/4"	36"	24" x 48"	48" x 72"	1 HP	115/1/60	38 sec.	750 lbs.
BD-36-050	5,000 lbs.	7 1/4"	36"	24" x 48"	48" x 72"	1 1/2 HP	230,460/3/60	22 sec.	770 lbs.
BD-36-060	6,000 lbs.	7 1/4"	36"	24" x 48"	48" x 72"	1 1/2 HP	230,460/3/60	30 sec.	790 lbs.
BD-36-080	8,000 lbs.	9"	36"	30" x 60"	54" x 84"	3 HP	230,460/3/60	21 sec.	1,350 lbs.
BD-48-020	2,000 lbs.	7 1/4"	48"	24" x 64"	48" x 88"	1 1/2 HP	230,460/3/60	19 sec.	850 lbs.
BD-48-040	4,000 lbs.	7 1/4"	48"	24" x 64"	48" x 88"	1 1/2 HP	230,460/3/60	32 sec.	900 lbs.
BD-48-060	6,000 lbs.	7 1/4"	48"	24" x 64"	48" x 88"	1 1/2 HP	230,460/3/60	39 sec.	950 lbs.
BD-48-080	8,000 lbs.	9"	36"	24" x 66"	48" x 96"	3 HP	230,460/3/60	30 sec.	1,350 lbs.
BD-60-020	2,000 lbs.	10"	60"	24" x 86"	48" x 120"	3.2 HP	460/3/60	10 sec.	1,300 lbs.
BD-60-040	4,000 lbs.	10"	60"	24" x 86"	48" x 120"	3.2 HP	460/3/60	20 sec.	1,375 lbs.
BD-60-060	6,000 lbs.	10"	60"	24" x 86"	48" x 120"	3.2 HP	460/3/60	30 sec.	1,450 lbs.
BD-60-080	8,000 lbs.	10"	60"	24" x 86"	48" x 120"	3.2 HP	460/3/60	42 sec.	1,700 lbs.

Wide Base Lift Tables - Base dimension is the same as standard platform. Other sizes available. Consult factory.

BD-36-020-W	2,000 lbs.	7 3/4"	36"	36" x 48"	60" x 72"	1 HP	115/1/60	44 sec.	1,020 lbs.
BD-36-040-W	4,000 lbs.	7 3/4"	36"	36" x 48"	60" x 72"	1 HP	115/1/60	46 sec.	1,070 lbs.
BD-36-060-W	6,000 lbs.	7 3/4"	36"	36" x 48"	60" x 72"	1 1/2 HP	230, 460/3/60	26 sec.	1,120 lbs.

Pan Style Lifts

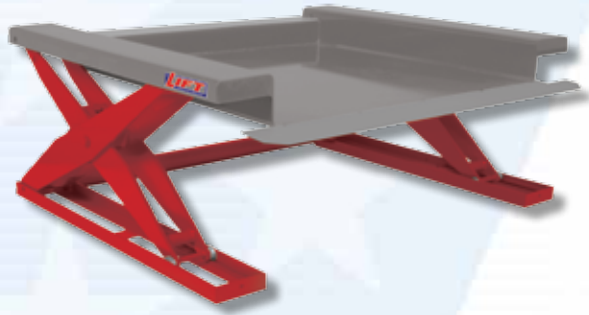

These unique lifts lower right to the floor so they can be accessed by hand pallet trucks.

- Two pan sizes to accommodate standard and oversized pallets
- 2,000 and 4,000 pound capacities
- 4 side accessibility
- 6" flexible safety toe guard
- External 1 HP 115/1/60 motor

Model	Capacity	Low Height	Vertical Travel	Pan Dimensions	Overall Dimension	Rise Time	Weight
PBD-44-020	2,000 lbs.	3/8"	35"	44" x 48"	61 1/4" x 59"	40 sec.	1,300 lbs.
PBD-44-040	4,000 lbs.	3/8"	35"	44" x 48"	61 1/4" x 59"	44 sec.	1,325 lbs.
PBD-50-020	2,000 lbs.	3/8"	35"	50" x 48"	67 1/4" x 59"	40 sec.	1,400 lbs.
PBD-50-040	4,000 lbs.	3/8"	35"	50" x 48"	67 1/4" x 59"	44 sec.	1,425 lbs.

Oversized Load Handling Lifts



Ideal for woodworking or other applications that involve feeding oversized sheets or panels. Our most popular models are shown in the table below.

- Extremely stable
- Available in 4,000 and 12,000 pound capacities
- Longer and wider platforms are available in a variety of capacities and lifting heights. Consult factory for special requirements.

Model	Capacity	Low Height	Vertical Travel	Standard Platform	Max Platform	Motor	Power	Rise Time	Weight
OPBD-36-040	4,000 lbs.	7 1/4"	36"	36" x 64"	48" x 96"	1 1/2 HP	230,460/3/60	32 sec.	900 lbs.
OPBD-36-060	6,000 lbs.	7 1/4"	36"	36" x 64"	48" x 96"	1 1/2 HP	230,460/3/60	39 sec.	950 lbs.
OPBD-36-080	8,000 lbs.	9"	36"	36" x 66"	48" x 96"	3.2 HP	460/3/60	30 sec.	1,350 lbs.
OPBD-48-080	8,000 lbs.	8"	48"	36" x 132"	48" x 168"	3.2 HP	460/3/60	36 sec.	1,950 lbs.
OPBD-48-120	12,000 lbs.	8"	48"	36" x 132"	48" x 168"	3.2 HP	460/3/60	54 sec.	2,050 lbs.
OPBD-60-080	8,000 lbs.	10"	60"	36" x 172"	48" x 204"	3.2 HP	460/3/60	40 sec.	2,700 lbs.
OPBD-60-120	12,000 lbs.	10"	60"	36" x 172"	48" x 204"	3.2 HP	460/3/60	60 sec.	2,850 lbs.

Wide Base Oversized Lift Tables - Base width is the same as standard platform width. Other sizes available. Consult factory

OPBD-36-040-W	4,000 lbs.	6 3/4"	36"	36" x 96"	60" x 120"	1 HP	115/1/60	42 sec.	1,350 lbs.
OPBD-36-080-W	8,000 lbs.	6 3/4"	36"	36" x 96"	60" x 120"	1 HP	115/1/60	84 sec.	1,450 lbs.
OPBD-36-120-W	12,000 lbs.	7 1/4"	36"	36" x 96"	60" x 120"	3.2 HP	460/3/60	44 sec.	1,600 lbs.

Dock Lifts

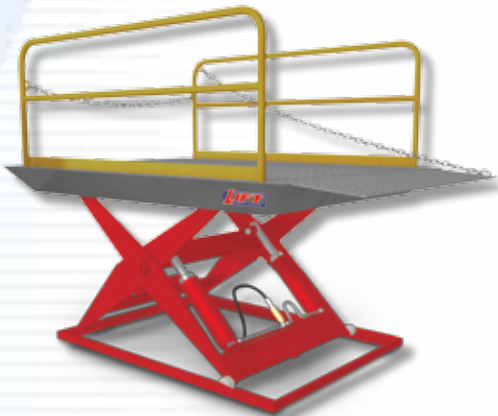

Move loads from any height truck to any height dock quickly and safely without the high cost of major dock construction.

- 59" of travel / 67 max. height
- Can be mounted in a pit for grade level access or on a concrete pad
- Energy efficient 3.2 HP motor
- More versatile than dock levelers
- Diamond tread deck and steel hand rails for safety
- Beveled toe guard platform

Model	Lift Capacity	Roll-Over Capacity	Low Height	Vertical Travel	Standard Platform	Max Platform	Throw-Over Plate	Rise Time	Weight
DLBD-59-050	5,000 lbs.	10,000 lbs.	8"	59"	6' x 8'	8' x 10'	18" x 60"	27 sec.	2,800 lbs.
DLBD-59-060	6,000 lbs.	10,000 lbs.	8"	59"	6' x 8'	8' x 10'	18" x 60"	27 sec.	2,900 lbs.
DLBD-59-080	8,000 lbs.	10,000 lbs.	10"	59"	6' x 8'	8' x 10'	18" x 60"	42 sec.	3,200 lbs.

Tilter Lifts



These tilting lifts position items at a comfortable height and angle for safe, easy access. Tilt angle automatically and uniformly increases as load is raised.

- Independent control of lift and tilt (UTBBD models only)
- Positioning of loads at any angle between 0° - 45°
- Lower edge lip keeps loads in place
- Greater angles and capacities available. Please consult factory

Model	Capacity	Low Height	Vertical Travel	Tilt Angle	Standard Platform	Minimum Platform*	Motor	Tilt Time	Weight
TLBD-45-020	2,000 lbs.	6"	17"	45°	18" x 42"	18" x 31"	1/2 HP	35 sec.	425 lbs.
TLBD-45-040	4,000 lbs.	7"	18"	45°	24" x 48"	24" x 36"	1 HP	35 sec.	770 lbs.
TLBD-45-060	6,000 lbs.	8"	17"	45°	24" x 48"	24" x 36"	1 HP	40 sec.	850 lbs.

*Minimum platform requires external pump unit.

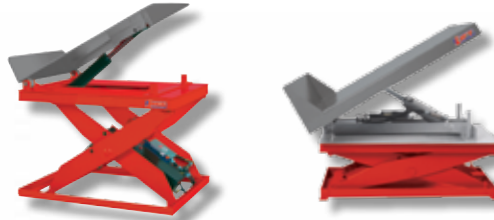

For applications that require independent control of lift and tilt functions, LiftCOA offers a variety of Lift and Tilt tables. Visit LiftCOA.com for details.

Floor/Platform Tilters



Mounted to optional 12" fixed height stand

Fixed height tilters / upenders position loads at any angle from horizontal to 45° or 90°.

- Can be floor mounted or placed on fixed height platform
- Infinite positioning at any angle between 0° - 45° or 0° - 90°
- Lower edge lip keeps loads in place
- Platforms sizes up to 60" x 60" are available

Model	Capacity	Low Height	Tilt Angle	Standard Platform	Max Platform	Motor	Tilt Time	Weight
FHTBD-45-020	2,000 lbs.	7 ½"	45°	24" x 36"	50" x 50"	1/2 HP	15 sec.	510 lbs.
FHTBD-45-040	4,000 lbs.	7 ½"	45°	24" x 36"	50" x 50"	1/2 HP	16 sec.	520 lbs.
FHTBD-90-020	2,000 lbs.	8 ½"	90°	36" x 42"	60" x 60"	1 HP	60 sec.	730 lbs.
FHTBD-90-040	4,000 lbs.	8 ½"	90°	36" x 42"	60" x 60"	1 HP	64 sec.	750 lbs.

Portable Container Tilters



Tilt wire baskets and containers to a comfortable angle to make accessing contents much easier without the need for bending.

- Portable design for maximum versatility
- 12V DC power with maintenance free battery
- Works with any open bottom container or basket*
- Push button pendant control

Model	Capacity	Low Height	Tilt Angle	Fork Length	Fork O.D.	Overall Dimensions	Tilt Time	Weight
CTBD-020	2,000 lbs.	3 ½"	89°	42"	26 ½"	34" x 62"	26 sec.	790 lbs.
CTBD-040	4,000 lbs.	3 ½"	89°	42"	26 ½"	34" x 62"	30 sec.	825 lbs.

*Straddle units are available for use with closed bottom containers or pallets. Consult factory for details.

Portable Electric Lift Tables



For transporting and vertically positioning loads. DC power lifts and lowers the platform at the touch of a button.

- Two fixed and two swivel casters for easy portability
- Oversized platforms available
- Foot operated floor lock for safety when used as a work surface
- Built-in battery charger

Model	Capacity	Low Height	Vertical Travel	Standard Platform	Max Platform	Rise Time	Battery	Weight
PELT-24-010	1,000 lbs.	9 ¼"	24"	24" x 36"	30" x 42"	10 sec.	12V	470 lbs.
PELT-24-015	1,500 lbs.	9 ¼"	24"	24" x 36"	30" x 42"	15 sec.	12V	475 lbs.
PELT-36-010	1,000 lbs.	9 ¼"	36"	24" x 48"	30" x 54"	14 sec.	12V	500 lbs.
PELT-36-015	1,500 lbs.	9 ¼"	36"	24" x 48"	30" x 54"	20 sec.	12V	505 lbs.
WPELT-24-010	1,000 lbs.	9 ¼"	24"	36" x 36"	42" x 42"	8 sec.	12V	460 lbs.
WPELT-24-015	1,500 lbs.	9 ¼"	24"	36" x 36"	42" x 42"	15 sec.	12V	465 lbs.
WPELT-36-010	1,000 lbs.	9 ¼"	36"	36" x 48"	48" x 54"	14 sec.	12V	490 lbs.
WPELT-36-015	1,500 lbs.	9 ¼"	36"	36" x 48"	48" x 54"	20 sec.	12V	495 lbs.
DPELT-30-010	1,000 lbs.	10 ¾"	30"	24" x 24"	30" x 30"	8 sec.	12V	470 lbs.
DPELT-36-010	1,000 lbs.	11 ¾"	36"	24" x 36"	30" x 42"	14 sec.	12V	505 lbs.
DPELT-36-015	1,500 lbs.	11 ¾"	36"	24" x 36"	30" x 42"	20 sec.	12V	515 lbs.
DPELT-48-010	1,000 lbs.	11 ¾"	48"	24" x 48"	30" x 54"	43 sec.	12V	650 lbs.
DPELT-48-015	1,500 lbs.	11 ¾"	48"	24" x 48"	30" x 54"	43 sec.	12V	700 lbs.

Portable Manual Lift Tables



Designed for lighter loads from 300 to 1,500 pounds. Foot pump operated hydraulics lift loads with no power required.

- Two fixed and two swivel casters for easy portability
- Hand release for controlled lowering
- Foot operated floor lock for safety when used as a work surface
- 1/2" steel scissor legs

Model	Capacity	Low Height	Vertical Travel	Standard Platform	Max Platform	Lifting Strokes	Weight
PMLT-24-003	300 lbs.	10"	23"	20" x 32"	20" x 32"	12	250 lbs.
PMLT-24-006	600 lbs.	10"	23"	20" x 32"	20" x 32"	25	260 lbs.
PMLT-24-010	1,000 lbs.	9 ¼"	24"	24" x 36"	30" x 42"	35	410 lbs.
PMLT-24-015	1,500 lbs.	9 ¼"	24"	24" x 36"	30" x 42"	55	415 lbs.
PMLT-24-020	2,000 lbs.	17 ½"	24"	24" x 36"	48" x 60"	85	750 lbs.
PMLTO-24-010	1,000 lbs.	9 ¼"	24"	36" x 36"	42" x 42"	35	450 lbs.
PMLTO-24-015	1,500 lbs.	9 ¼"	24"	36" x 36"	42" x 42"	55	455 lbs.
PMLTO-36-010	1,000 lbs.	9 ¼"	36"	36" x 48"	48" x 54"	46	480 lbs.
PMLTO-36-015	1,500 lbs.	9 ¼"	36"	36" x 48"	48" x 54"	69	485 lbs.

Hand Pallet Trucks



Solid, reliable, and economical hand pallet trucks move palletized loads quickly and easily throughout the plant or warehouse.

- Solid steel forks and chassis
- Powder coated finish
- Nylon steer and load wheels
- Articulating steer axle
- Cushioned handle with three function control

Model	Capacity	Low Height	Lift Height	Overall Width (OD)	Fork Length	Fork Width	Steer Wheels	Weight
HPT-55-2748	5,500 lbs.	2 7/8"	7 5/8"	27"	48"	7"	7" x 2"	170 lbs.
HPT-55-2148	5,500 lbs.	2 7/8"	7 5/8"	21 1/4"	48"	7"	7" x 2"	170 lbs.

High Lift Pallet Trucks - Manual



Can be used to lift and transport pallet/skid loads or as a manual palletizer. Pallet truck style handle, manually lifts loads up to 32".

- Combines the best features of a hand pallet truck and a lift table
- Works with any open bottom pallet or skid
- Stabilizers prevent unit from moving when raised

Model	Capacity	Low Height	Lift Height	Lift Strokes (empty/full)	Overall Width (OD)	Fork Length	Weight
HLPT-25-21-M	2,500 lbs.	3 1/2"	32"	30/60	21 1/4"	45"	244 lbs.
HLPT-25-27-M	2,500 lbs.	3 1/2"	32"	30/60	27"	45"	244 lbs.
HLPT-30-21-M	3,000 lbs.	3 1/2"	32"	30/60	21 1/4"	45"	244 lbs.
HLPT-30-27-M	3,000 lbs.	3 1/2"	32"	30/60	27"	45"	244 lbs.

High Lift Pallet Trucks - Electric



A pallet/skid transporter with the added convenience of push button electric lift.

- Combines the best features of a hand pallet truck and a lift table
- Works with any open bottom pallet or skid
- Stabilizers prevent unit from moving when raised

Model	Capacity	Low Height	Lift Height	Overall Width (OD)	Fork Length	Battery	Built-In Charger	Weight
HLPT-22-21-E	2,200 lbs.	3 1/2"	31 1/2"	21 1/4"	44"	12VDC (70Ah)	110V, 15A	375 lbs.
HLPT-22-27-E	2,200 lbs.	3 1/2"	31 1/2"	27"	44"	12VDC (70Ah)	110V, 15A	375 lbs.

Custom Design and Manufacturing is Never a Problem

Does your application require something more than what you see in this catalog? Don't worry. We have the application experience and engineering support to customize a product specifically for you.

If you've got an application problem and no idea how to solve it we can start from square one and engineer a solution for you. Or, if you've already got an idea of how to solve a problem, we'll help you refine it and turn it into a real product. Either way we guarantee a hassle free process and finished product that does exactly what you need it to do.



Options & Accessories

Our lifts can be equipped with several standard accessories to make them even more versatile.



Portability

- Semi-Live*
- Casters*
- Power Traverse*
- Push Bars*

Performance

- High Cycle Lifts*
- Continuous Duty*
- Power Units*

Power/Controls

- Airbag/Pneumatic Actuation*
- Push Button/Foot Controls*
- Special Power Units*
- Travel Limit Switches*
- Quick Disconnect*
- NEMA Rated*

Platforms/Bases

- Tilt Tops*
- Conveyor Tops*
- Turntables*
- Vee Cradles*
- Fixed Height Sub Bases*
- Narrow Bases*
- Extra Wide Bases*
- Tandem Bases*

Safety

- Accordion/Bellows*
- Photo Electric Sensors*
- Safety Roll Curtain*
- Hand Rails*
- Beveled Toe Guard*

Paint/Finish

- Custom Colors*
- Epoxy Paint*
- Cold Galvanizing*



LIFT COMPANY OF AMERICA
P.O. BOX 124, GREENSBURG, IN. 47240
PH: 877-515-8297 • FAX: 812-222-2013
www.LiftCOA.com